

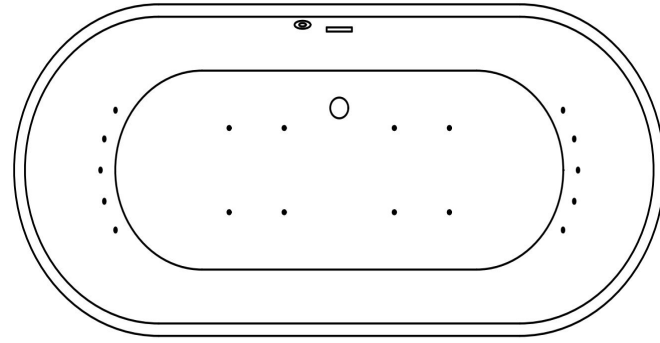

Tub Configurations



Napoli71CAJ (Air Jet)

(Electrical: 1x 110V 15A GFCI)

Standard Feature: Air Blower

Optional Features: Chromotherapy Light, Ozone Sanitizing

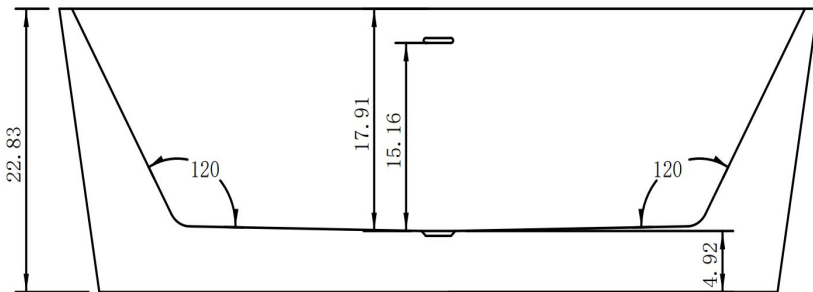
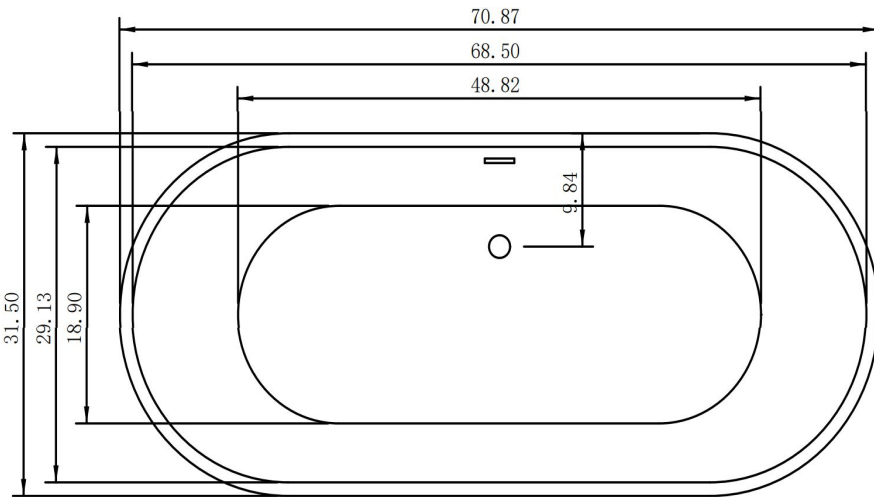

Napoli71C (Soaker)

General Specifications

Installation	Freestanding
Material	High Gloss Acrylic Sheet Reinforced with Fiberglass and Resin
Weight	121 lbs - Soaker 131 lbs - Air Jet
Depth to Overflow	15.16"
Water Capacity (with Bather*)	77 gal (52 gal)

Drain Requirement

Required pop-up drain and 1.5" drain hub included
Can use Slip Joint or Quick Connect Drain (Not Supplied)
Tub supplied with leveling pads for uneven floors

Component Legend

-  Activation Button
-  Air Wall Jet
-  Air Floor Jet

Codes/Standards

ASME A112.19.702020/CSA B45.10:20*
CSA B45.5/IAPMO Z124-2017
UL 1795*
MA Code Accepted

