

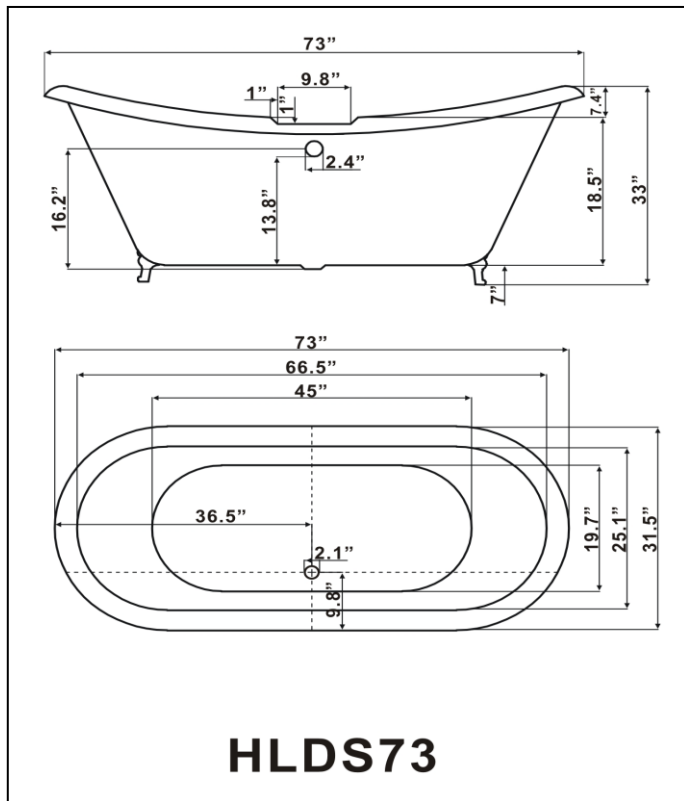

## HLDS73

Double Slipper Clawfoot Tub with Deck Area for Faucet



Meets or Exceeds ANSI Z124.1.2-2005; CSA B45.0-02 & CSA B45.5-02

### Weights

Weight empty	161 lbs
Weight filled to overflow	746 lbs
Gallons to overflow	73

### General

- Reinforced extra thick floor
- Slip resistant floor
- High gloss interior and exterior
- Integrated aluminum heat barrier
- Minimum tub thickness 3/4"

cUPC label on base of tub



Manufactured by;

Baths of Distinction Inc. 5843 Carrier St, St. Petersburg, Florida USA 33714